

ALUMINCO[®]
ALUMINIUM BUILDING SYSTEMS



SL320

SLIDING-LIFT AND SLIDE,
NON-INSULATED NEW
GENERATION SYSTEM.

SUPER SMART & SLIM

The smartest, sliding - lift and slide non-insulated, new generation aluminium system we have ever designed and will make you review your expectations so far.

ALUMINCO SL320 IS THE SLIDE - LIFT AND SLIDE SYSTEM THAT UPGRADES THE BASIC FUNCTIONS OF A SLIDING SYSTEM AND INCORPORATES SMART FEATURES PREVIOUSLY HELD BY HIGHER-END SYSTEMS.

The frame's exceptional design, with straight fine lines perfectly matches current architectural trends that call for minimal design, ensures a lightweight system and comes out in a number of typologies that can cover a range of needs, suitable for large constructions as well.

With sliding and lift and slide mechanisms and a number of alternative solutions, it is the most suitable system for areas of warmer climate.

- ▶ **Interlocking profile width of only 30 mm to maximize transparency and light penetration.**



THE ALL IN SYSTEM PACKAGE!

- ▶ Lighter than ever, comes in various typologies, adapts to large-scale constructions.
- ▶ High level of aesthetic functionality.
- ▶ Minimal style and straight lines in combination with the low threshold option of 30 mm height offer particularly elegant structures and facilitate the access.
- ▶ Meeting style width of only 70 mm.
- ▶ The built-in handle at the junction point of the slim hook offers increased resistance to wind load.
- ▶ Wide range of configurations with sliding and Lift & Slide mechanisms.
- ▶ Smooth and easy sliding.
- ▶ Solutions for small, medium and large openings.

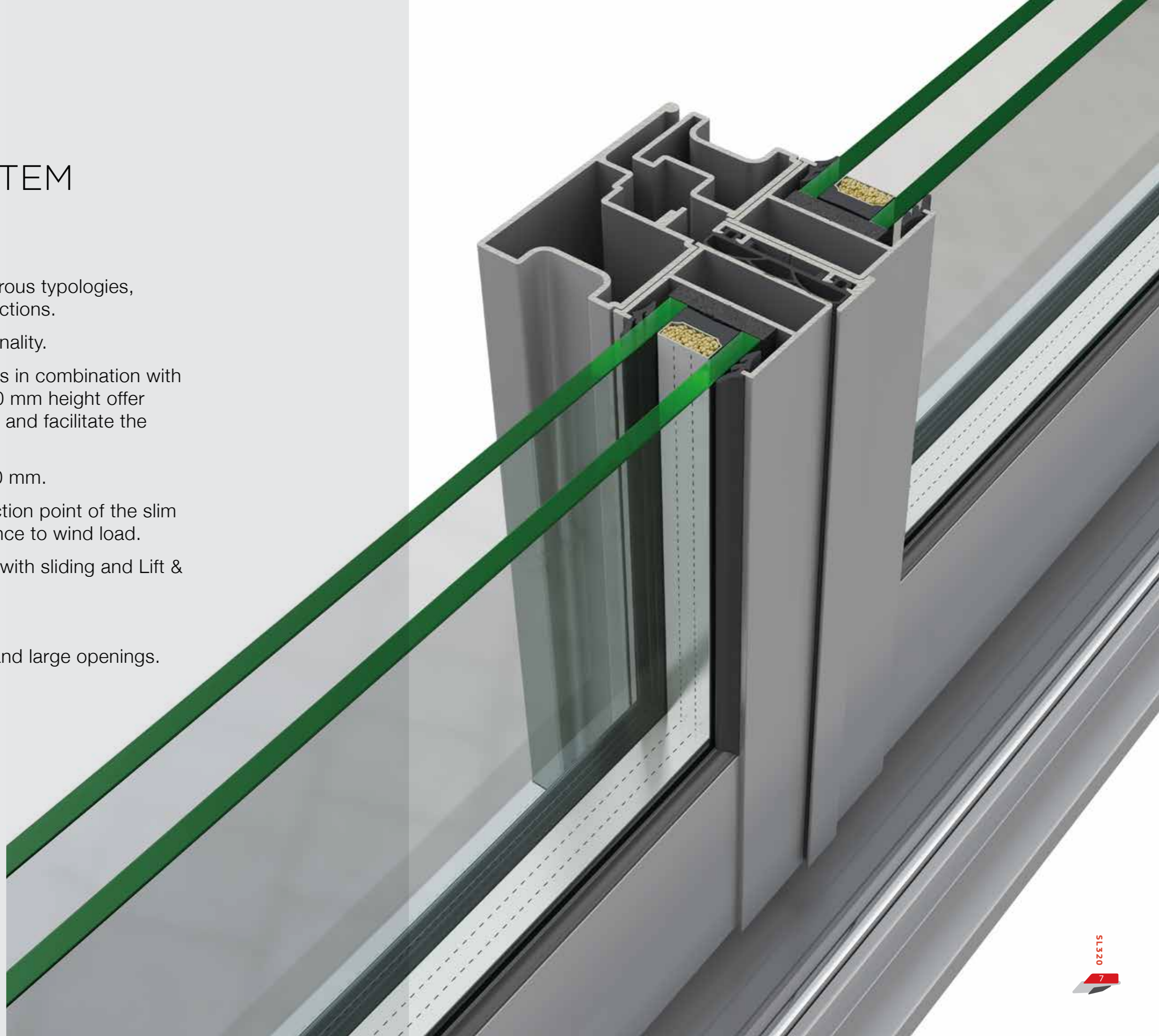

EXTREMELY ADAPTABLE

Revel in more style and modernity, the small given details are in accordance with everyone's wishes.

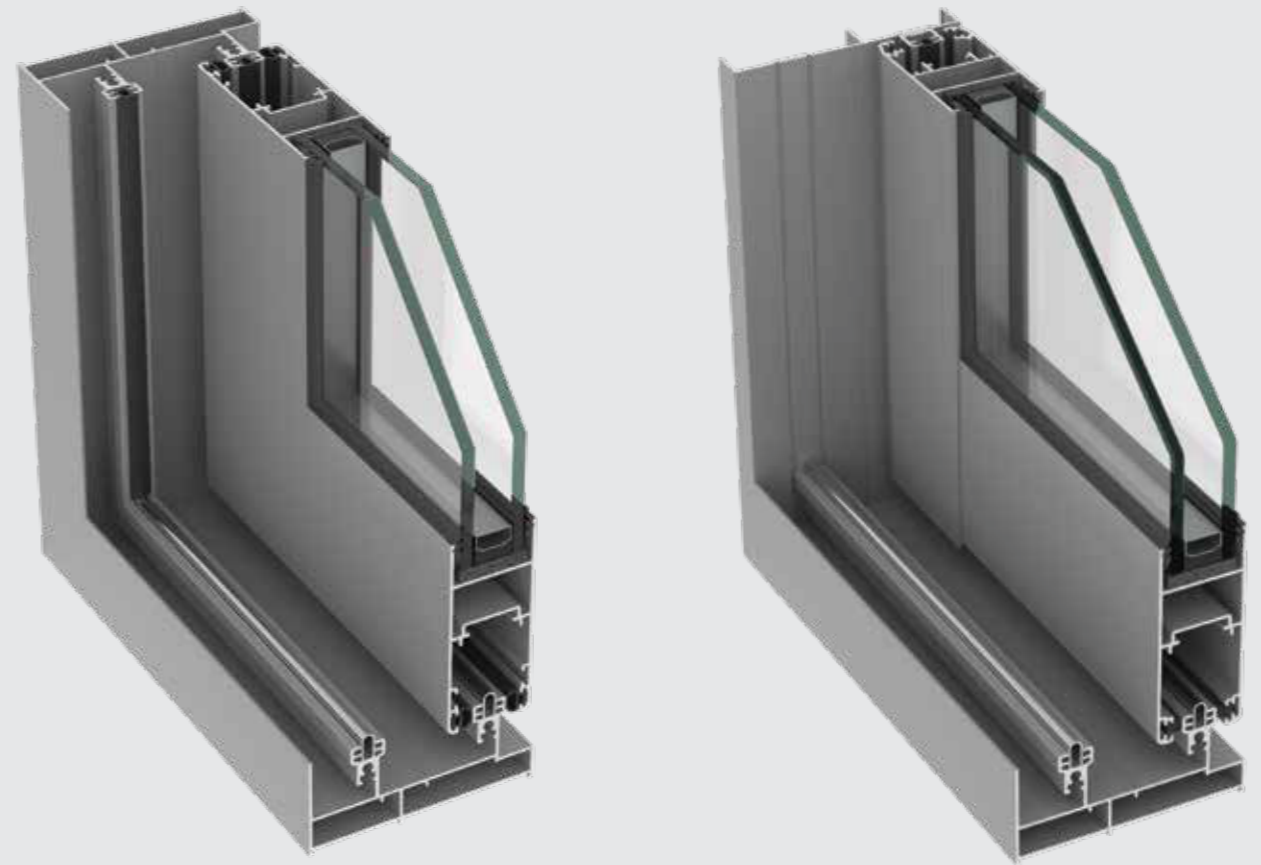

Sash profiles for 45° and 90° assembling.



Hanging insect screen with a very thin frame provides a viewless aluminium style

TECHNICAL CHARACTERISTICS

HARDWARE

SLIDING	•
LIFT & SLIDE	•

SYSTEM PROFILE DIMENSIONS

FRAME LIFT & SLIDE WIDTH mm	86
MIN. FRAME HEIGHT mm	30
MIN. FACE HEIGHT mm	97.5
GLASS THICKNESS mm	24
SASH WIDTH mm	32
SASH HEIGHT mm	76
INTERLOCKING PROFILE WIDTH mm	30

CONSTRUCTION DIMENSIONS

SASH WIDTH mm	330-2000
SASH HEIGHT mm	520-2800
MAX. SASH DIMENSIONS mm (WxH)	2000x2400 / 1700x2800
MAX. SASH WEIGHT Kg	120 / 200*

*Lift and slide mechanism

CONFIGURATIONS

Sliding: 2Leaf sliding, 3Leaf sliding, 4Leaf double sliding, 6Leaf double sliding, 2Leaf sliding with insect screen

Sliding in wall: 1leaf-2leaf glazing, 1leaf-2leaf glazing/mosquito screen, 1leaf-2leaf glazing/ shutter, 1leaf-2leaf glazing/mosquito screen/shutter.

Combinations: 2Leaf sliding SL320 with opening W540, 2Leaf sliding with mosquito screen SL320 with opening W540, 3Leaf sliding SL320 with opening W540.

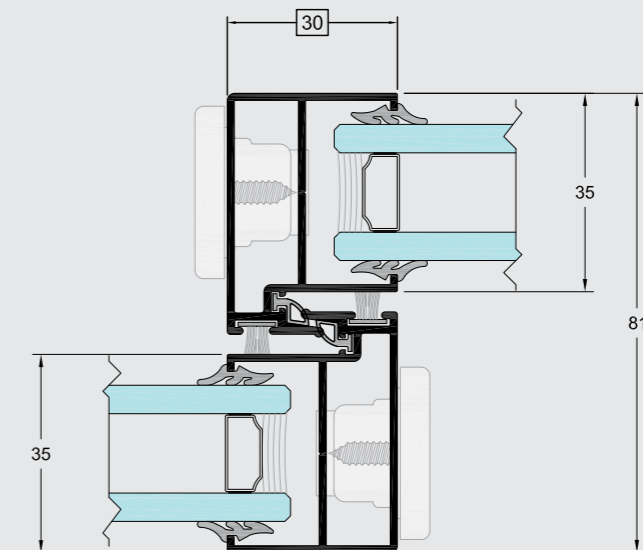
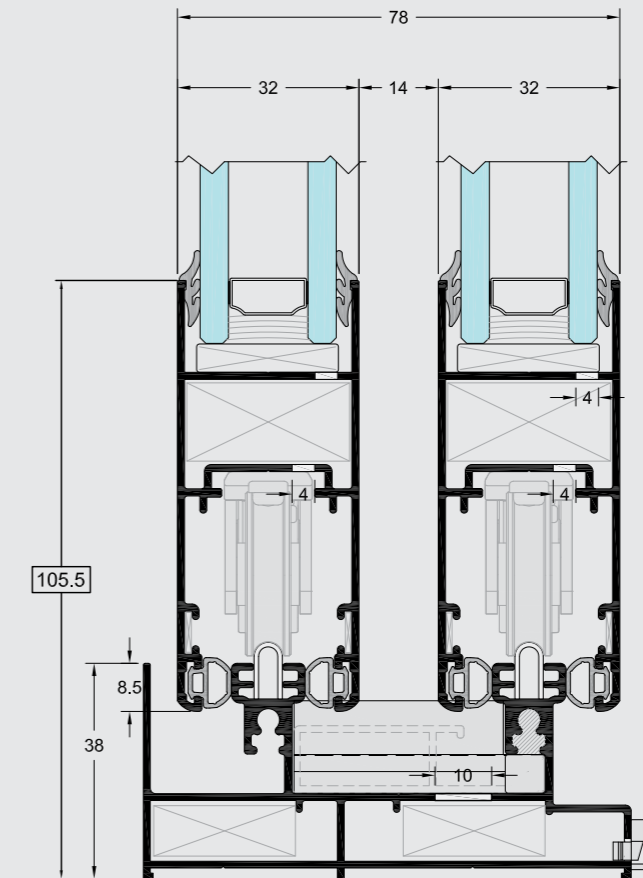



Inofita, Viotia GR-32011- Greece
T. +30 22620 47000 ■ F. +30 22620 47090
www.aluminco.com ■ info@aluminco.com